

## BEARINGS

The main function of the bearing is to minimize friction between two elements with relative rotational movement between them and to ensure smooth load transfer. The bearing is an element of every rotating mechanism. A perfect bearing creates a perfect mechanism. Bearings are used in reducers, fans and pumps, machine tool shafts, automobile shafts, axles, gearboxes, belt tensioning systems, alternators and steering systems, water pumps and doors, all kinds of industrial electric motors, washing machines and vacuum cleaners, agricultural machines, heavy machinery, wind turbines, in short, all kinds of rotating mechanisms.



**Figure 1:** Examples of bearing models

### Bearing Components

In general, bearings consist of 4 main elements. These elements are the outer ring, inner ring, steel balls that provide rolling movement and cages used to prevent contact between balls, respectively.

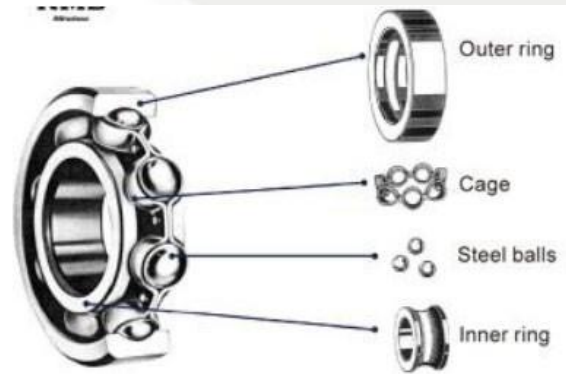

**Figure 2:** Bearing components



## Bearing Assembly

Determining how the bearing should fit before bearing assembly is the first step; when designing the seat and shaft in which the bearing is installed, care must be taken to ensure that the bearing fits sufficiently tightly in the seat and shaft. In general, the outer and inner rings of the bearings do not rotate at the same time. In principle, whichever ring is rotating, it is acceptable for that ring to fit tightly to the housing (the outer ring to the slot, the inner ring to the shaft), and the non-rotating ring to fit hollow (free). However, there are many factors that prevent compliance with this general rule and affect how much hollow (free) fit and tight fit should be. One of these factors is the type and amount of the load.

**Environmental Load:** If the load is fixed and the ring is rotating, or the ring is fixed and the load is rotating, there is an environmental load.

**Point Load:** If the ring does not rotate and the load is fixed or the load rotates with the ring, there is a point load.

**Indeterminate Load:** If there is both environmental and point load, there is indeterminate load.

The circumferential load bearing ring must be fitted to the seat or shaft with a tight fit. The greater the load, the tighter the fit. Hollow (free) fit should be preferred in the seats and shafts to which the point load bearing ring is attached. For indeterminate loads, both the shaft and the slot should be designed with a tight fit. Since tight fits reduce the operating clearance of the bearing (radial or axial), attention should be paid to the bearing operating clearance when selecting bearings. Higher clearance bearings should be preferred if necessary. Bearings are machine elements that are machined with high precision and operate under high loads. In order to take full advantage of the capacities of the bearings, it is necessary to take into account the selection of the bearing type and structure and the installation and disassembly conditions during the construction of the peripheral elements. The use of appropriate mounting tools, the necessary care in assembly and the cleanliness of the installation location are the most important conditions that extend the life of the bearing.

**NEARLY 20% OF ALL BEARING PROBLEMS ARE CAUSED BY POOR ASSEMBLY TECHNIQUES**

**Tight Fits:** For many bearings, the inner ring or outer ring (in some cases both) is fitted to the tight fit shaft or housing.

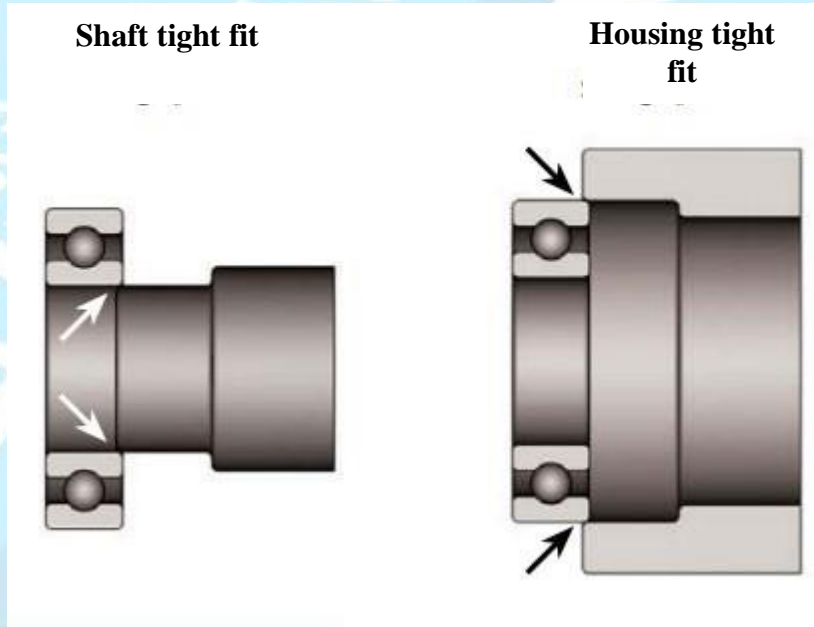

**Figure 3:** Bearing shaft and housing tight fit

**Incorrect Assembly:** In the cold assembly of bearings, it must be ensured that the assembly force is always applied to the tight fit ring. Mounting forces should never be applied over rotating elements. The rolling path can be damaged by applying force to the wrong bearing ring.

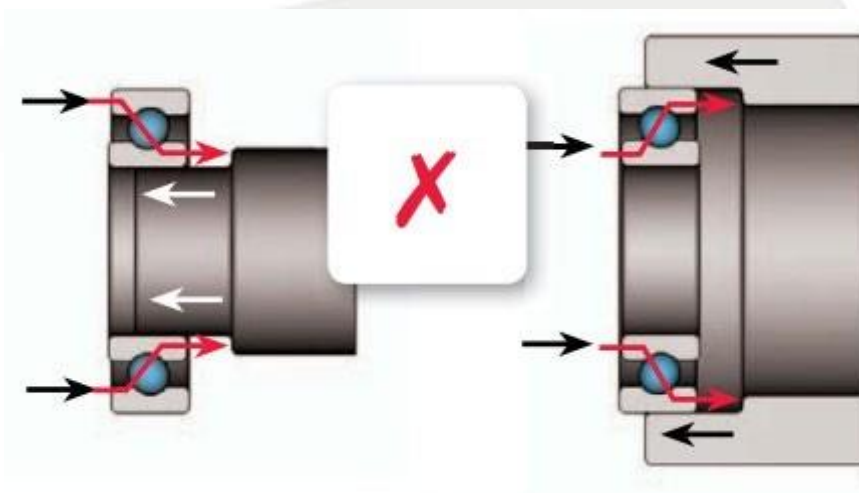

**Figure 4:** Load on the balls due to faulty bearing fit

**Correct Assembly:** With specially designed mounting tools, the risk of damage to the rolling path can be minimized. Rolling path damage can be prevented with the right tools.

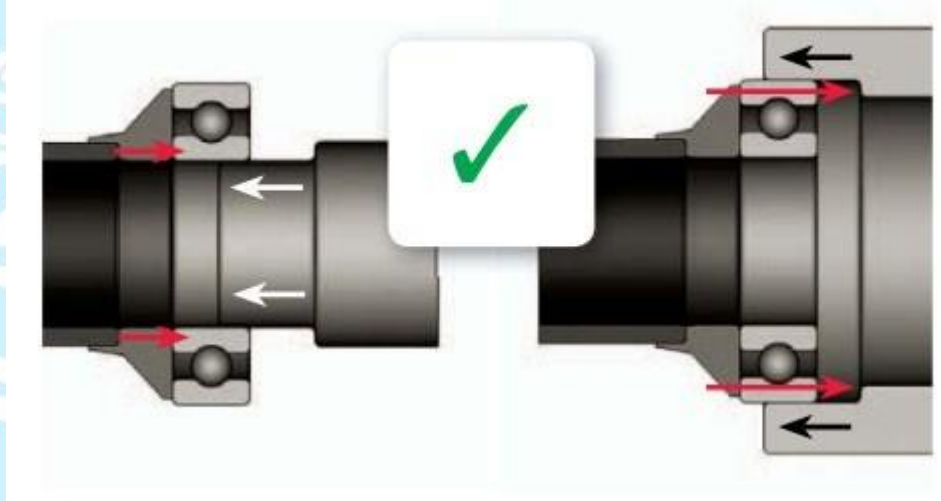

**Figure 5:** Preventing damage to the rolling path with the right mounting technique

### **Dismantling of Bearings**

Dismantling the bearings is a necessary part of routine maintenance and care must be taken to ensure that no components are damaged during the procedure. Due to the structure of most machine bodies, high extraction force is required to overcome the force between the bearing shaft or housing and the bearing. In addition, access is required to remove it. Conventional methods, such as the use of hammers and sliding tools or local heating, can remove burrs on the shaft or housings and result in costly damage by causing heat-induced deterioration. Bearing removal tools can be used to ensure that the bearing is removed both safely and without damaging the surrounding components. These include mechanical extraction tools and hydraulic pullers, which can be combined with adjustable three-section thrust plates to ensure good contact with the bearing rings.



**Figure 6:** Bearing disassembly process



There are 3 types of assembly commonly used during the bearing assembly phase.

### 1. Cold Assembly

It is used for small and medium-sized bearings where force is applied to achieve the required tightness of fit. It can be done by impact or by pressing. The force is usually applied unevenly and to the defective part of the bearing, so that all the force is applied to the rotating elements of the bearing and causes permanent damage.



**Figure 7:** Bearing driving by cold mounting

### Equipment Used in Cold Assembly

First of all, the correct equipment selection should be made according to the element (shaft or slot) where the bearing will fit tightly. Because it is necessary to apply force to the ring where there will be a tight fit during assembly. Otherwise, since the load will pass over the balls, it may cause deterioration in the rolling slot and ball form.



## 1. Assembly Tool Kits

It is a frequently used method for small and medium-sized bearings. However, the selection of the right apparatus for the right bearing is of high importance. Various bearing companies have standard bearing assembly tool kits designed according to standard bearings.



**Figure 8:** Assembly tool kit

The sample assembly tool kit and the bearing catalog to which it is applied are as follows;







### **Assembly Tool Kit FTN333**

This tool kit is designed for fast, precise and safe assembly of bearings with internal diameters of 10-50 mm. The correct combination of impact rings and sleeve ensures that mounting forces are never applied to the rolling elements of the bearing.

- Impact rings are made of high shock-resistant material.
- With the special design of the impact rings, the force is transferred to the bearing rings.
- The nylon double-sided hammerhead effectively prevents damage.
- It is suitable for attaching bushings, seals, pulleys, etc.
- Impact collars and impact sleeve are available separately.
- Impact hammer is included in FTN333-H.
- Mechanical damage to the bearing does not occur during the cold assembly process.



**Figure 9:** Mounting tool kit FTN333

Used for the following bearing series						
						
6000 - 6015	129	7202B - 7213B	3200 - 3213	21304 - 21311	204 - 213	30302 - 30310
6208 - 6213	1200 - 1213	7303B - 7311B	3302 - 3311	22205/10	2204 - 2210	30203 - 30210
6300 - 6311	2200 - 2213		5200 - 5213	22205 - 22213	304 - 311	32203 - 32210
6404 - 6410	1300 - 1311		5302 - 5311	22308 - 22311	2304 - 2310	32304 - 32310
16002 - 16013	2301 - 2311				1005 - 1010	31305 - 31310
98203 - 98206					305 - 311	33205 - 33210
					405 - 410	

**Figure 10:** Bearing series for which the mounting tool kit FTN333 can be used



## 2. Bearing Puller Tool Kits

The puller set can remove deep groove ball bearings from both shafts and bearings without damaging the surrounding components. Thanks to the axial movement in the form of a screw step, transitions are possible without shocks. Assembly is also possible in some cases with these tools.

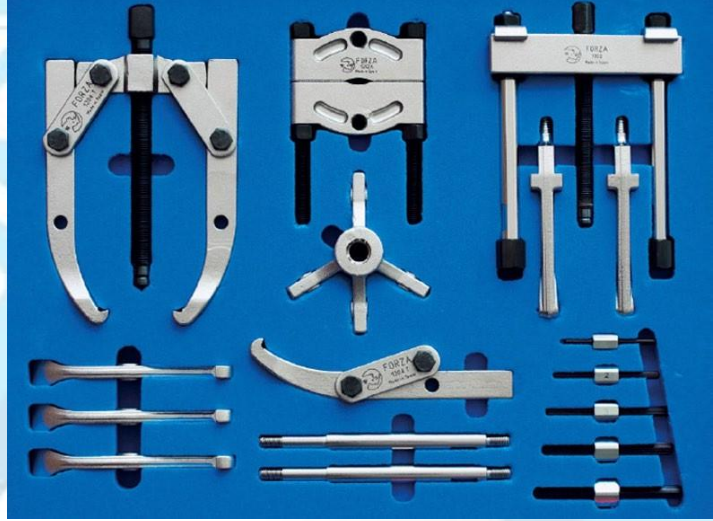

**Figure 11:** Bearing puller tool set

Sample puller set and applied bearing catalog are as follows;

### **Bearing Puller Kit BPN32**

The BPN62 tool kit allows easy removal of ball bearings without removing the shaft in most cases. It consists of six pull handle sets and two supporting spindles, and is suitable for deep groove ball bearings with a shaft diameter between 10-100 mm.

- It weighs only 3.2 kg and the box has a set of six pull handles and two shafts.
- The bearing has articulated pull handles for power transmission.
- It is user-friendly thanks to its elastic lock ring that keeps the pull handles in the correct position.
- The pull handles are made of high-quality steel.
- Inside the box is a selection chart for deep groove ball bearings.





**Figure 12: Bearing pull kit BPN32**

Ball bearing type						
60..	62..	63..	64..	62../63..	16...	161..
6000 - 6020	6200 - 6217	6300 - 6313	6403 - 6410	62/22 62/28 63/22 63/28	16002 - 16011	16100 16101

**Figure 13: Bearing puller kit series**



### 3. Crescent Wrenches

It is specially designed to insert and remove the lock nut in the tapered shaft and sleeve assembly.

Standard and high impact models are available.



**Figure 14:** Use of crescent wrench

#### Crescent Switch Specifications

Locknut wrenches are designed for safe installation and removal of locknuts without causing the resulting damage when other methods are used.

- It is a simple and inexpensive method used in the assembly of lock nuts in tapered hole assembly.
- Suitable for shafts, taper and adapter sleeves.
- The correct position at the lock nut, clamping into the slot guarantees the lock nut is undamaged.
- It is a standard series made of thick steel plate.
- Easy-grip impact carrier design where forged steel head is welded to alloy steel handle.
- Large head impact carrier design resistant to heavy loads and hard impacts.



## 2. Hot Assembly

An alternative to methods where direct force is applied is the use of heat to expand the bearing rings. This allows the bearing to be mounted by sliding it easily on the shaft. However, heating the bearing requires a uniform and precise application. Although traditionally oil baths or bearing baths are used, these methods are quite difficult and may potentially cause problems. A much more effective method is to use a special bearing induction heater. There are various induction heaters that meet different electrical power and bearing weight needs. All of them have an automatic heating cycle, which includes measuring and monitoring the bearing temperature. Efficient and fast heating process is provided together with the desired ring temperature control for easy application.

### Equipment Used in Hot Assembly

Induction-heated assembly equipment can be used during hot assembly. Since relatively small diameter and weight bearings are used in our company, assembly can be carried out with the simplest induction devices.

Bearing heaters, with specially designed induction coils, allow the bearings to be heated safely and efficiently to the optimum temperature to facilitate hot assembly.



**Figure 15:** Bearing induction heater



## Appropriate Heater Selection for Applications

Bearing heaters specially designed for bearings of all sizes and weights are available. The choice of induction heater largely depends on the geometric dimensions and weight of the workpiece to be heated. The chart serves as a guide in the selection.

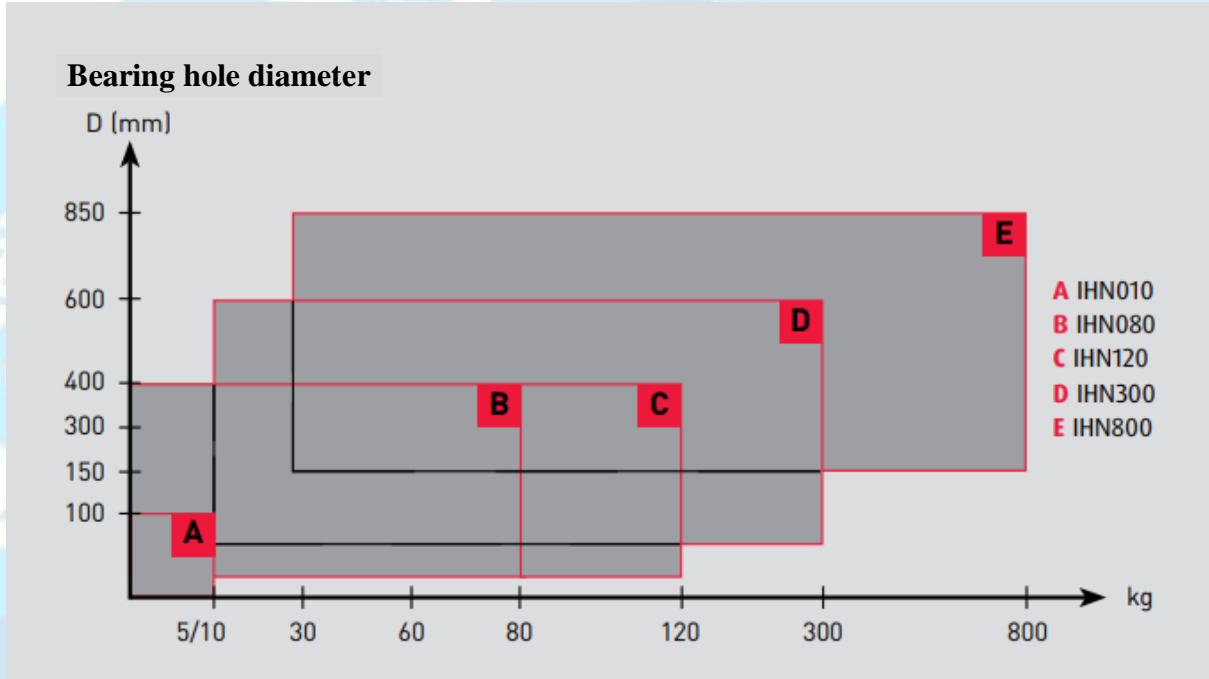

Figure 16: Heater selection chart

As can be seen in the chart, although the bearings used in our company are Class A bearings, it may be appropriate to use the IHN010 heater model rather than other models.

### IHN010 Induction Heater

- Portable, compact and very light (3.5kg).
- A bearing weighing 5 kg can be heated up to 110°C in less than four minutes.
- Quiet operation feature.
- A support yoke is not required, it is only necessary to insert the workpiece into the device.
- Predictive Temperature Control (PTC) software is available for automatic temperature monitoring.



**Figure 17:** IHN010 induction heater

### 3. Hydraulic Assembly

The use of hydraulic tools allows the force required to ensure proper installation of larger bearings. This is suitable for bearings fitted to the tapered shaft or sleeve. There are also hydraulic nuts, hydraulic pumps and hydraulic pullers/extractors for axial pull-up methods. With these tools, high forces are applied evenly and in a controlled manner, which allows the bearing to be installed or removed easily. This method is more preferred in large diameter and heavy bearings. Even if it is possible to use it for small diameter bearings, it does not seem to make much sense in terms of cost.

#### Useful Links

<https://www.youtube.com/watch?v=3nBPfuWLusg>

<https://www.youtube.com/watch?v=EpOiRu04eus>

[https://www.youtube.com/watch?v=QZmkqr-q\\_WY](https://www.youtube.com/watch?v=QZmkqr-q_WY)

<https://www.youtube.com/watch?v=vILnBkmAdWE>

[https://www.youtube.com/watch?v=\\_ThgjGJR52k](https://www.youtube.com/watch?v=_ThgjGJR52k)

<https://www.youtube.com/watch?v=Xp-BhQ-rWlc>

<https://www.youtube.com/watch?v=2yIeVG2dxkE>



## CONCLUSION

The bearing assembly process is a delicate process that requires effort and patience. Because although bearings can withstand great forces, their exposure to a force opposite to their design can cause them to deteriorate very easily. As a result of these deteriorations, high noise in the gearboxes may cause problems such as loss of efficiency, high temperature, and even the inability of the gearbox to operate as a result of mechanical failures. It can also cause deformation of the oil seals as a result of high temperatures, and one of the causes of oil leaks can be attributed to the deformation of the bearings. In order to prevent this and such situations, the situations mentioned in the report should be carefully examined and correct orientations should be applied.